

10 l/s Vaclon pump

Pump body

919-5005

Magnet

911-0030

Manuale di Istruzioni
Bedienungshandbuch
Notice de Mode D'Emploi
User Manual

87-900-139-01(A)

01/2012



Agilent Technologies

Notices

© Agilent Technologies, Inc. 2011

No part of this manual may be reproduced in any form or by any means (including electronic storage and retrieval or translation into a foreign language) without prior agreement and written consent from Agilent Technologies, Inc. as governed by United States and international copyright laws.

Manual Part Number

Publication Number: 87-900-139-01(A)

Edition

Edition 01/2012

Printed in ITALY

Agilent Technologies Italia S.p.A.

Vacuum Products Division

Via F.lli Varian, 54

10040 Leini (TO)

ITALY

Warranty

The material contained in this document is provided “as is,” and is subject to being changed, without notice, in future editions. Further, to the maximum extent permitted by applicable law, Agilent disclaims all warranties, either express or implied, with regard to this manual and any information contained herein, including but not limited to the implied warranties of merchantability and fitness for a particular purpose. Agilent shall not be liable for errors or for incidental or consequential damages in connection with the furnishing, use, or performance of this document or of any information contained herein. Should Agilent and the user have a separate written agreement with warranty terms covering the material in this document that conflict with these terms, the warranty terms in the separate agreement shall control.

Technology Licenses

The hardware and/or software described in this document are furnished under a license and may be used or copied only in accordance with the terms of such license.

Restricted Rights Legend

If software is for use in the performance of a U.S. Government prime contract or subcontract, Software is delivered and licensed as “Commercial computer software” as defined in DFAR 252.227-7014 (June 1995), or as a “commercial item” as defined in FAR 2.101(a) or as “Restricted computer software” as defined in FAR 52.227-19 (June 1987) or any equivalent agency regulation or

contract clause. Use, duplication or disclosure of Software is subject to Agilent Technologies’ standard commercial license terms, and non-DOD Departments and Agencies of the U.S. Government will receive no greater than Restricted Rights as defined in FAR 52.227-19(c)(1-2) (June 1987). U.S. Government users will receive no greater than Limited Rights as defined in FAR 52.227-14 (June 1987) or DFAR 252.227-7015 (b)(2) (November 1995), as applicable in any technical data.

Trademarks

Windows and MS Windows are U.S. registered trademarks of Microsoft Corporation.

Safety Notices

CAUTION

A **CAUTION** notice denotes a hazard. It calls attention to an operating procedure, practice, or the like that, if not correctly performed or adhered to, could result in damage to the product or loss of important data. Do not proceed beyond a **CAUTION** notice until the indicated conditions are fully understood and met.

WARNING

A **WARNING** notice denotes a hazard. It calls attention to an operating procedure, practice, or the like that, if not correctly performed or adhered to, could result in personal injury or death. Do not proceed beyond a **WARNING** notice until the indicated conditions are fully understood and met.

10 l/s Vaclon

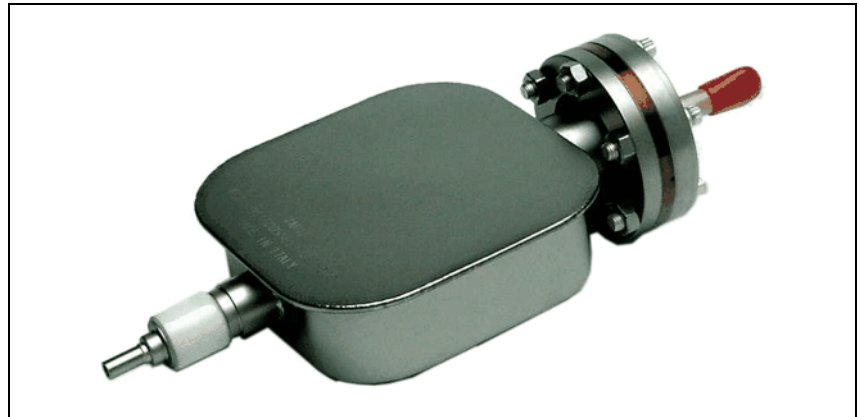

Contents

1	Procedura per l'installazione	9
	Informazioni generali	10
	Preparazione per l'installazione	11
	Installazione	13
	Usò	15
	Procedure di uso	16
	Manutenzione	17
	Smaltimento	18
2	Anleitung zur Installation	19
	Allgemeine Hinweise	20
	Vor der Installation	21
	Installation	23
	Gebrauch	25
	Bedienungsschritte	26
	Wartung	27
	Entsorgung	28
3	Procédure pour l'installation	29
	Indications générales	30
	Préparation de l'installation	31

Contents

Installation	33
Utilisation	35
Procédure d'utilisation	36
Maintenance	37
Mise au rebut	38
4 Installation procedure	39
General Information	40
Preparation for Installation	41
Installation	43
Use	45
Operating Procedure	46
Maintenance	47
Disposal	48
5 Technical Information	49
10 l/s Vaclon Pump Controllers	49
Description of the Vaclon Pump	50
Technical Specification	51
Outline Drawing	54
Stray Magnetic Field	55
Vaclon Pump Installation	58
Typical Installation	61
Inlet Flange Connection	62

Control Unit Connection 63

Pump Connection 64

Bakeout Operation 64

Pump Speed & Noble Gases 66

Maintenance 67

10 l/s Vaclon Pump Replacement Parts and Accessories 70

10 l/s Vaclon Pump Controllers 71

Contents

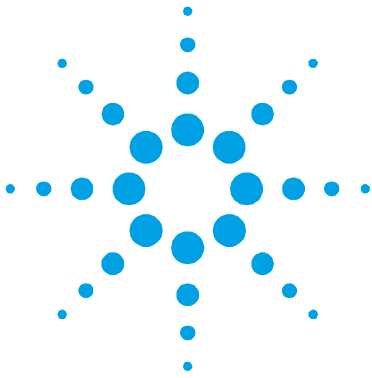

1 Procedura per l'installazione

Informazioni generali	10
Preparazione per l'installazione	11
Installazione	13
Uso	15
Procedure di uso	16
Manutenzione	17
Smaltimento	18

Traduzione delle istruzioni originali



Informazioni generali

Questa apparecchiatura è destinata ad uso professionale. L'utilizzatore deve leggere attentamente il presente manuale di istruzioni ed ogni altra informazione addizionale fornita da Agilent prima dell'utilizzo dell'apparecchiatura. Agilent si ritiene sollevata da eventuali responsabilità dovute all'inosservanza totale o parziale delle istruzioni, ad uso improprio da parte di personale non addestrato, ad interventi non autorizzati o ad uso contrario alle normative nazionali specifiche.

Le pompe della serie VacIon sono pompe ioniche utilizzate comunemente per applicazioni di ultra alto vuoto, grazie alla loro pulizia, capacità di pompare qualsiasi tipo di gas, e del loro funzionamento senza vibrazioni e necessità di manutenzione.

Nei paragrafi seguenti sono riportate tutte le informazioni necessarie a garantire la sicurezza dell'operatore durante l'utilizzo dell'apparecchiatura. Informazioni dettagliate sono fornite nell'appendice "Technical Information".

Questo manuale utilizza le seguenti convenzioni:

AVVERTENZA!



I messaggi di avvertenza attirano l'attenzione dell'operatore su una procedura o una pratica specifica che, se non eseguita in modo corretto, potrebbe provocare gravi lesioni personali.

ATTENZIONE!

I messaggi di attenzione sono visualizzati prima di procedure che, se non osservate, potrebbero causare danni all'apparecchiatura.

NOTA

Le note contengono informazioni importanti estrapolate dal testo.

Preparazione per l'installazione

La pompa viene fornita in un imballo protettivo speciale; se si presentano segni di danni, che potrebbero essersi verificati durante il trasporto, contattare l'ufficio vendite locale.

Durante l'operazione di disimballaggio, prestare particolare attenzione a non lasciar cadere la pompa e a non sottoporla ad urti o vibrazioni.

Non disperdere l'imballo nell'ambiente. Il materiale è completamente riciclabile e risponde alla direttiva CEE 85/399 per la tutela dell'ambiente.

ATTENZIONE!

Onde evitare problemi di degassamento, non toccare con le mani nude i componenti destinati ad essere esposti al vuoto. Utilizzare sempre i guanti o altra protezione adeguata.

NOTA

La pompa non può essere danneggiata rimanendo semplicemente esposta all'atmosfera. Si consiglia comunque di mantenerla chiusa fino al momento dell'installazione sul sistema onde evitare eventuale inquinamento da polvere.

1 Procedura per l'installazione
Preparazione per l'installazione



Figura 1

Installazione

Non installare e/o utilizzare la pompa in ambienti esposti ad agenti atmosferici (pioggia, gelo, neve), polveri, gas aggressivi, in ambienti esplosivi o con elevato rischio di incendio. Durante il funzionamento, per ottenere le specifiche tecniche dichiarate, la temperatura ambiente deve essere compresa tra 0 °C e +85 °C.

ATTENZIONE! La pompa deve essere tenuta sigillata con il suo tubo di ingresso schiacciato finché non è pronta per essere collegata al sistema.

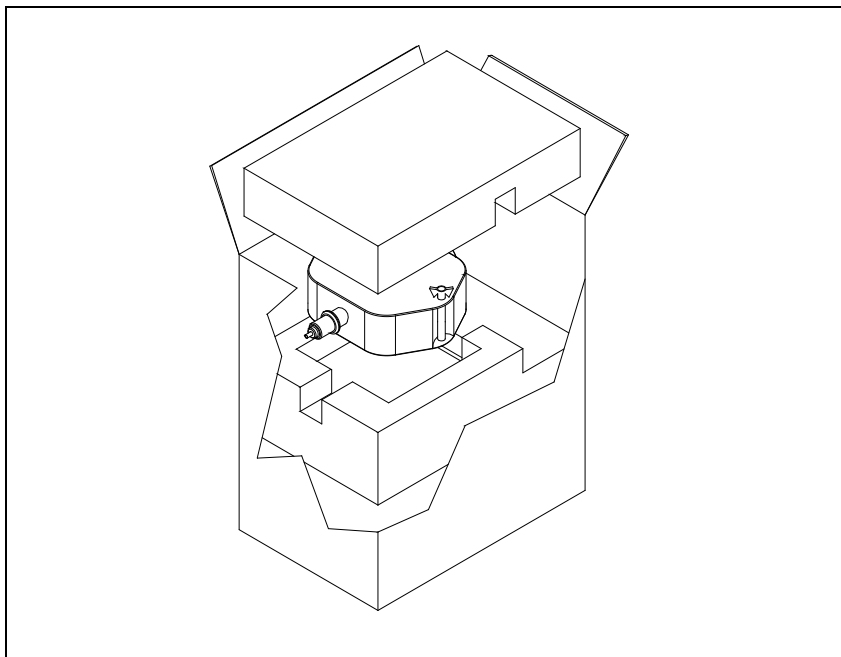

Figura 2

AVVERTENZA! Per evitare lesioni alla persona, non collegare l'alta tensione alla pompa prima che sia installata nel sistema e che tutte le flange di ingresso siano adeguatamente collegate o chiuse.

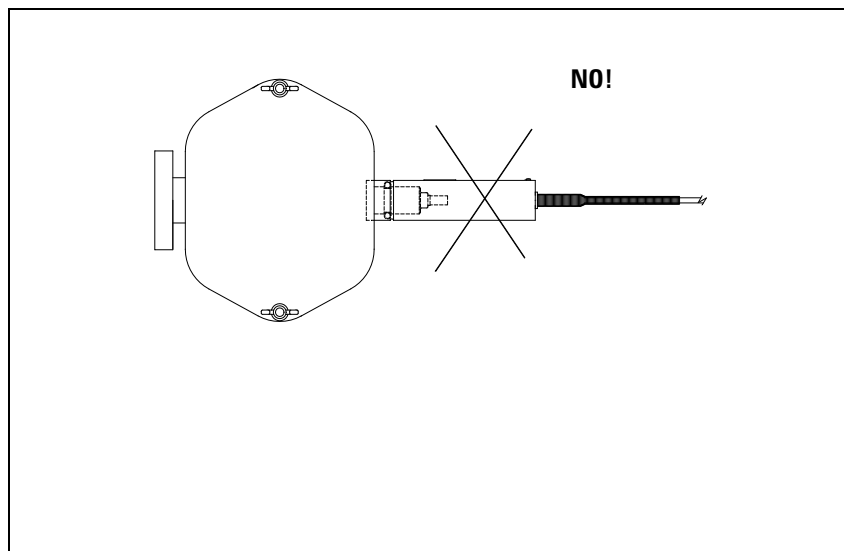

1 Procedura per l'installazione

Installazione

Il funzionamento delle pompe è ottimizzato solo con l'uso delle apposite unità di controllo Agilent (4UHV o MiniVac).

ATTENZIONE! Il rispetto delle normative di sicurezza nell'uso delle pompe è garantito solo con l'uso delle unità di controllo Agilent.

La pompa VacIon può essere installata in qualsiasi posizione. Per convenienza normalmente viene montata in posizione verticale con la flangia di ingresso in alto, o in posizione orizzontale.

Le pompe possono anche essere mantenute sospese in ogni posizione tramite la loro flangia di ingresso.

Per informazioni dettagliate sull'installazione della pompa, vedere l'appendice "Technical Information".

Uso

Tutte le istruzioni per il corretto funzionamento delle pompe Vaclon sono contenute nel manuale dell'unità di controllo.

Leggere attentamente tale manuale prima dell'utilizzo.

Depositi igroscopici e l'assorbimento dell'idrogeno all'interno del composto di titanio possono provocare l'allungamento del tempo di avvio con l'invecchiamento della pompa. Durante l'esposizione all'aria, il deposito del composto di titanio assorbe vapore acqueo; in conseguenza di ciò, al successivo avvio, il riscaldamento della pompa provoca il rilascio del vapore e di parte dell'idrogeno pompato precedentemente, con l'effetto dell'allungamento del tempo di avvio.

Procedure di uso

Controllare che la polarità dell'unità di controllo sia corretta per la pompa.

Fare riferimento al relativo manuale ed osservare la seguente procedura per l'uso della pompa:

- 1 Tramite una pompa di pre-vuoto portare il sistema ad una pressione di 1×10^{-4} mbar, meglio se 10^{-5} , od inferiore.
- 2 Collegare l'unità di controllo ad una apposita fonte di alimentazione ed accenderla.
- 3 Osservare la tensione, la corrente e la pressione. Un valore di corrente prossimo alla corrente di corto circuito dell'unità di controllo è indice dell'esistenza di una perdita nella pompa o nel sistema. Un temporaneo incremento della pressione di pre-vuoto è normale durante la fase di avvio.
- 4 Lasciare la valvola di prevuoto aperta durante l'avvio della pompa ionica finchè non si raggiunge una adeguata pressione di avvio. Se la tensione della pompa ionica scende dopo la chiusura della valvola, riaprirla per un pre-pompaggio aggiuntivo. Appena la pressione diminuisce, la tensione cresce nuovamente e la valvola di pre-vuoto deve essere chiusa.
- 5 Quando si porta la pompa alla pressione atmosferica, usare azoto secco in modo da evitare l'assorbimento di vapore acqueo da parte delle pareti della pompa.

AVVERTENZA!



Quando la pompa viene utilizzata per il pompaggio di gas tossici, infiammabili o radioattivi, seguire le appropriate procedure tipiche di ciascun gas. Non usare la pompa in presenza di gas esplosivi.

AVVERTENZA!



Non toccare la pompa durante le operazioni di riscaldamento e di raffreddamento. L'elevata temperatura può causare lesioni alle persone.

ATTENZIONE!

Non avvicinare dispositivi elettronici alla pompa. Il campo magnetico attorno ad essa può provocare dei malfunzionamenti dei dispositivi stessi.

Manutenzione

Le pompe della serie Vaclon non richiedono alcuna manutenzione. Qualsiasi intervento deve essere eseguito da personale autorizzato.

AVVERTENZA!



Prima di effettuare qualsiasi intervento sulla pompa scollegarla dall'alta tensione.

Qualora una pompa dovesse essere rottamata, procedere alla sua eliminazione nel rispetto delle normative nazionali specifiche.

1 Procedura per l'installazione

Smaltimento

Smaltimento

Significato del logo "WEEE" presente sulle etichette.

Il simbolo qui sotto riportato applicato in ottemperanza alla direttiva CE denominata "WEEE".

Questo simbolo (**valido solo per i paesi della Comunità Europea**) indica che il prodotto sul quale è applicato, **NON** deve essere smaltito insieme ai comuni rifiuti domestici o industriali, ma deve essere avviato ad un sistema di raccolta differenziata.

Si invita pertanto l'utente finale a contattare il fornitore del dispositivo, sia esso la casa madre o un rivenditore, per avviare il processo di raccolta e smaltimento, dopo opportuna verifica dei termini e condizioni contrattuali di vendita.

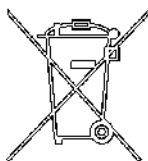

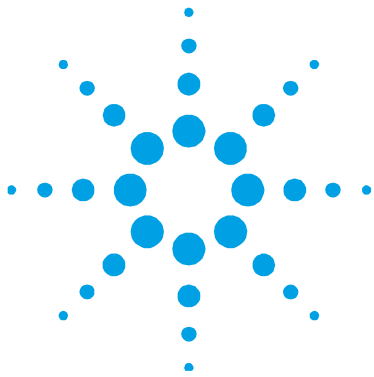

2

Anleitung zur Installation

Allgemeine Hinweise	20
Vor der Installation	21
Installation	23
Gebrauch	25
Bedienungsschritte	26
Wartung	27
Entsorgung	28

Übersetzung der Originalanleitungen



Allgemeine Hinweise

Dieses Gerät ist für den professionellen Gebrauch bestimmt. Vor dem Gebrauch soll der Benutzer dieses Handbuch sowie alle weiteren von Agilent mitgelieferten Zusatzdokumentationen genau lesen. Bei vollständiger bzw. teilweiser Nichtbeachtung der enthaltenen Hinweise, unsachgemäßem Gebrauch durch ungeschultes Personal, nicht autorisierten Eingriffen und Mißachtung der nationalen Bestimmungen übernimmt Firma Agilent keinerlei Haftung.

Die Pumpen der Serie VacIon sind Ionenzerstäuberpumpen, die aufgrund ihrer Reinheit, ihrer Fähigkeit, alle Arten von Gas zu pumpen, und ihres vibrations- und wartungsfreien Betriebes, allgemein für Ultrahochvakuumanwendungen zum Einsatz kommen.

In den folgenden Abschnitten sind alle erforderlichen Informationen für die Sicherheit des Bedieners bei der Anwendung des Geräts aufgeführt. Detaillierte technische Informationen sind im Anhang "Technical Information" enthalten.

In dieser Gebrauchsanleitung werden Sicherheitshinweise folgendermaßen hervorgehoben:

WARNUNG!



Die Warnhinweise lenken die Aufmerksamkeit des Bedieners auf eine spezielle Prozedur oder Praktik, die bei unkorrekter Ausführung schwere Verletzungen hervorrufen könnte.

VORSICHT!

Die Vorsichtshinweise vor bestimmten Prozeduren machen den Bediener darauf aufmerksam, daß bei Nichteinhaltung Schäden am Gerät entstehen können.

HINWEIS

Die Hinweise enthalten wichtige Informationen, die aus dem Text hervorgehoben werden.

Vor der Installation

Die Pumpe wird in einer speziellen Schutzverpackung geliefert. Eventuelle Transportschäden sind der zuständigen örtlichen Verkaufsstelle zu melden.

Beim Auspacken vorsichtig vorgehen, damit die Pumpe nicht fällt oder Stößen oder Vibrationen ausgesetzt wird.

Das Verpackungsmaterial ist ordnungsgemäß zu entsorgen. Es ist vollständig recyclebar und entspricht der EG-Richtlinie 85/399 für den Umweltschutz.

VORSICHT!

Um Ausgasungsprobleme zu vermeiden, dürfen die Komponenten, die mit dem Vakuum in Kontakt kommen, nicht mit bloßen Händen berührt werden. Stets Handschuhe oder einen anderen geeigneten Schutz tragen.

HINWEIS

Die Pumpe kann, wenn sie einfach der Atmosphäre ausgesetzt ist, nicht beschädigt werden. Sie sollte jedoch bis zur Installation an der Anlage geschlossen bleiben, um Verunreinigungen durch Staub zu vermeiden.

2 Anleitung zur Installation

Vor der Installation



Abbildung 1

Installation

Die Pumpe darf nicht in Umgebungen installiert und/oder benutzt werden, die ungeschützt vor Witterungsbedingungen (Regen, Frost, Schnee), Staub und aggressiven Gasen sind, und in denen Explosions- und erhöhte Brandgefahr besteht.

Während des Betriebes soll die Umgebungstemperatur zwischen 0 °C und +85 °C betragen, um die angegebenen technischen Merkmale zu gewährleisten.

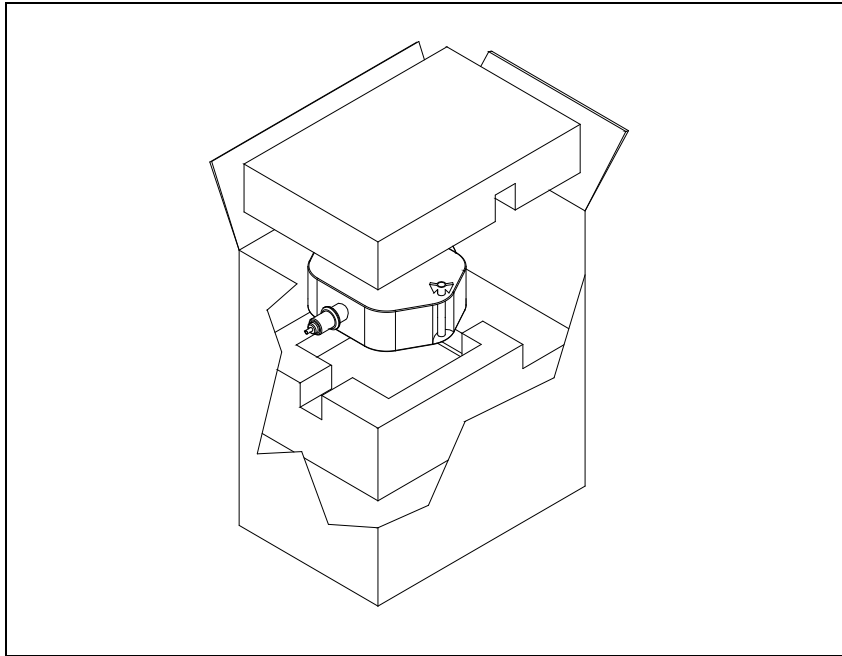
VORSICHT!

Die Pumpe soll versiegelt und mit verschlossener Eingangsöffnung aufbewahrt werden, bis sie für den Anschluß an das System bereit ist.



Abbildung 2

2 Anleitung zur Installation

Installation

WARNUNG!

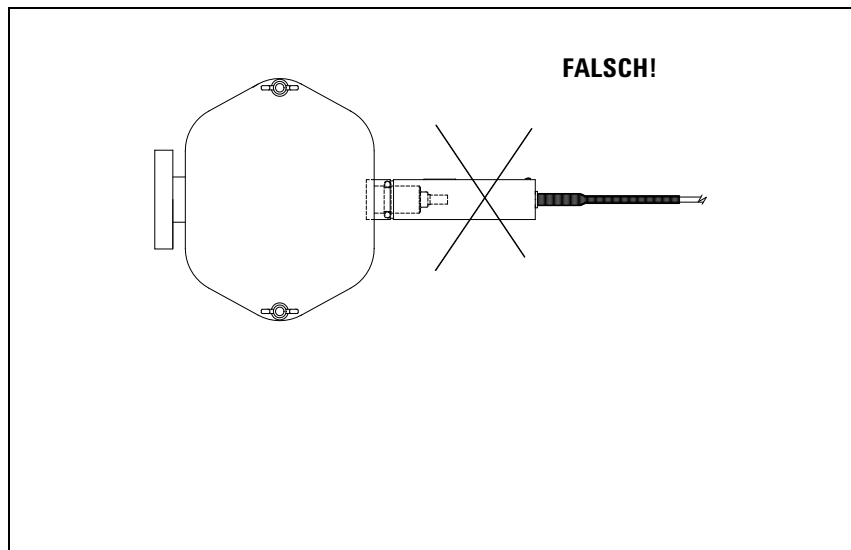

Um Personenschäden zu vermeiden, darf die Hochspannungsleitung der Pumpe erst angeschlossen werden, wenn die Pumpe im System installiert ist und alle Eintrittsflansche entsprechend angeschlossen oder geschlossen sind.

Der Pumpenbetrieb wird nur durch den Einsatz speziell dafür vorgesehener Agilent Steuereinheiten (4UHV oder MiniVac) optimiert.

VORSICHT!

Die Einhaltung der Sicherheitsvorschriften beim Gebrauch der Pumpen ist nur bei Verwendung von Agilent Steuereinheiten gewährleistet.

Die Pumpe VacIon kann in einer beliebigen Position installiert werden. Aus praktischen Gründen wird sie in der Regel senkrecht mit nach oben gerichtetem Eintrittsflansch oder waagrecht eingebaut.

Die Pumpen können auch in einer beliebigen Position an ihrem Eintrittsflansch hängend eingebaut werden.

Detaillierte Informationen zur Installation der Pumpe sind dem Anhang "Technical Information" zu entnehmen.

Gebrauch

Sämtliche Hinweise für den korrekten Betrieb der Pumpen VacIon sind im Handbuch der Steuereinheit enthalten.

Dieses Handbuch ist vor der Inbetriebnahme genau durchzulesen.

Hygroskopische Ablagerungen und die Absorption von Wasserstoff in der Titanverbindung können die Anlaufzeit verlängern und eine kürzere Standzeit der Pumpe verursachen. Die Ablagerungen der Titanverbindungen absorbieren Wasserdampf, wenn sie der Luft ausgesetzt werden. Dadurch bewirkt beim anschließenden Anlaufvorgang die Aufheizung der Pumpe die Abgabe des Dampfes und eines Teils des zuvor gepumpten Wasserstoffs, so daß sich die Anlaufzeit verlängert.

Bedienungsschritte

Es ist zu kontrollieren, daß die Steuereinheit in bezug auf die Pumpe richtig gepolt ist.

Es ist nach dem diesbezüglichen Handbuch vorzugehen, für den Gebrauch der Pumpe sind die folgenden Bedienungsschritte zu beachten:

- 1 Mittels einer Vorvakuumpumpe das System auf einen Druck von 1×10^{-4} , besser 10^{-5} mbar oder einen niedrigeren Druck bringen.
- 2 Die Steuereinheit an eine entsprechende Versorgungsquelle anschließen und einschalten.
- 3 Die Spannung, die Stromstärke und den Druck beobachten. Ein Stromwert, der sich dem Kurzschlußstromwert der Steuereinheit annähert, weist auf eine Leckstelle an der Pumpe oder am System hin. Ein zeitweiliger Anstieg des Vorvakuumdruckes ist während der Anlaufphase normal.
- 4 Während des Anlaufes der Ionenpumpe soll das Vorvakuumventil geöffnet bleiben, bis ein angemessener Anlaufdruck erreicht ist. Wenn die Spannung der Ionenpumpe nach Schließung des Ventils abfällt, ist das Ventil für eine zusätzliche Vorvakuumpumpung zu öffnen. Sobald der Druck sinkt, steigt die Spannung erneut an und ist das Vorvakuumventil zu schließen.
- 5 Wenn die Pumpe auf den atmosphärischen Druck gebracht wird, ist trockener Stickstoff zu verwenden, um die Aufnahme von Wasserdampf durch die Pumpenwände zu verhindern.

WARNUNG!

Wenn die Pumpe zur Förderung von giftigen, leicht entflammaren oder radioaktiven Gasen benutzt wird, sind die für das jeweilige Gas vorgeschriebenen Vorgänge zu befolgen. Die Pumpe nie bei Vorhandensein von explosivem Gas benutzen.

WARNUNG!



Darf die Pumpe während der Aufheizung und Abkühlung nicht berührt werden. Die hohe Temperatur kann zu Personenschäden führen.

VORSICHT!

Keine elektronischen Geräte in die Nähe der Pumpe bringen. Das darum befindliche Magnetfeld kann zu Funktionsstörungen der Geräte führen.

Wartung

Die Pumpen der Serie VacIon erfordern keine Wartung. Sämtliche Eingriffe dürfen nur von autorisiertem Personal vorgenommen werden.

WARNUNG!



Vor Eingriffen an der Pumpe ist diese von der Hochspannungsquelle zu trennen.

Bei eventueller Verschrottung einer Pumpe ist diese entsprechend der einschlägigen nationalen Vorschriften zu entsorgen.

2 Anleitung zur Installation

Entsorgung

Entsorgung

Bedeutung des "WEEE" Logos auf den Etiketten.

Das folgende Symbol ist in Übereinstimmung mit der EU-Richtlinie WEEE (Waste Electrical and Electronic Equipment) angebracht.

Dieses Symbol (**nur in den EU-Ländern gültig**) zeigt an, dass das betreffende Produkt nicht zusammen mit Haushaltsmüll entsorgt werden darf sondern einem speziellen Sammelsystem zugeführt werden muss.

Der Endabnehmer sollte daher den Lieferanten des Geräts - d.h. die Muttergesellschaft oder den Wiederverkäufer - kontaktieren, um den Entsorgungsprozess zu starten, nachdem er die Verkaufsbedingungen geprüft hat.

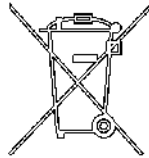



3

Procédure pour l'installation

Indications générales	30
Préparation de l'installation	31
Installation	33
Utilisation	35
Procédure d'utilisation	36
Maintenance	37
Mise au rebut	38

Traduction de la mode d'emploi originale



3 Procédure pour l'installation

Indications générales

Indications générales

Cet appareillage a été conçu en vue d'une utilisation professionnelle. Il est conseillé à l'utilisateur de lire attentivement cette notice d'instructions ainsi que toute autre indication supplémentaire fournie par Agilent avant d'utiliser l'appareil. Agilent décline toute responsabilité en cas de non respect total ou partiel des instructions fournies, d'opérations non autorisées, d'utilisation impropre par du personnel non formé ou contraires aux réglementations nationales spécifiques.

Grâce à leur propreté, à leur capacité de pomper tous les types de gaz, à leur fonctionnement sans vibrations et à l'absence d'entretien, les pompes de la série Vaclon sont des pompes ioniques généralement utilisées pour des applications de vide ultra poussé.

Les paragraphes suivants fournissent toutes les indications nécessaires à garantir la sécurité de l'opérateur pendant l'utilisation de l'appareillage. Des renseignements plus détaillés se trouvent dans l'appendice "Technical Information".

Cette notice utilise les signes conventionnels suivants:

AVERTISSEMENT!



Les messages d'avertissement attirent l'attention de l'opérateur sur une procédure ou une manœuvre spéciale dont la mauvaise exécution risque de provoquer de graves lésions.

ATTENTION!

Les messages d'attention apparaissent avant certaines procédures dont le non-respect peut endommager sérieusement l'appareillage.

NOTE

Les notes contiennent des renseignements importants, extrapolés du texte.

Préparation de l'installation

La pompe est fournie dans un emballage de protection spécial; si l'on constate des signes d'endommagement imputables au transport, contacter aussitôt le revendeur local.

Pendant l'opération de déballage, veiller tout particulièrement à ne pas laisser tomber la pompe et à ne lui faire subir aucun choc ni aucune vibration.

Ne pas abandonner l'emballage dans la nature. Le matériel est entièrement recyclable et il est conforme à la directive CEE 85/399 en matière de protection de l'environnement.

ATTENTION!

En vue d'éviter tout problème de dégazage, ne pas toucher à mains nues les éléments devant être exposés au vide. Mettre toujours des gants ou toute autre protection appropriée.

NOTE

La pompe ne peut être endommagée si elle reste simplement exposée à l'atmosphère. Il est quoi qu'il en soit conseillé de ne pas la retirer de son emballage avant le moment de l'installation, afin d'éviter toute pollution due à la poussière.

3 Procédure pour l'installation

Préparation de l'installation

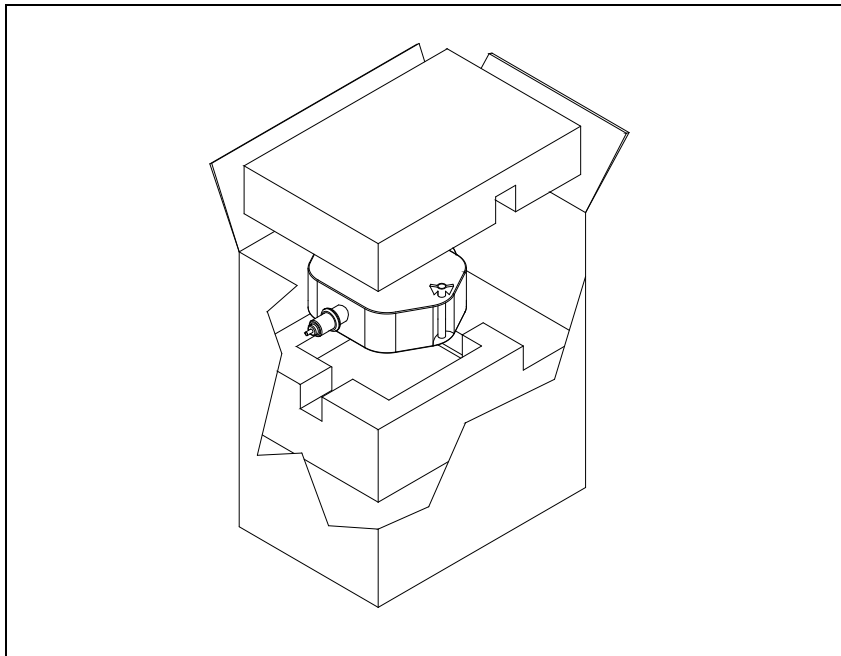

Figure 1

Installation

Ne pas installer et/ou utiliser la pompe dans des milieux exposés à des agents atmosphériques (pluie, gel, neige), à des poussières, à des gaz de combat ainsi que dans des milieux explosifs ou à fort risque d'incendie. Pendant le fonctionnement, pour respecter les spécifications techniques déclarées la température ambiante doit être comprise entre 0 °C et +85 °C;

ATTENTION!

La pompe doit être conservée scellée avec son tuyau d'entrée aplati jusqu'à ce qu'elle soit prête à être branchée au système.

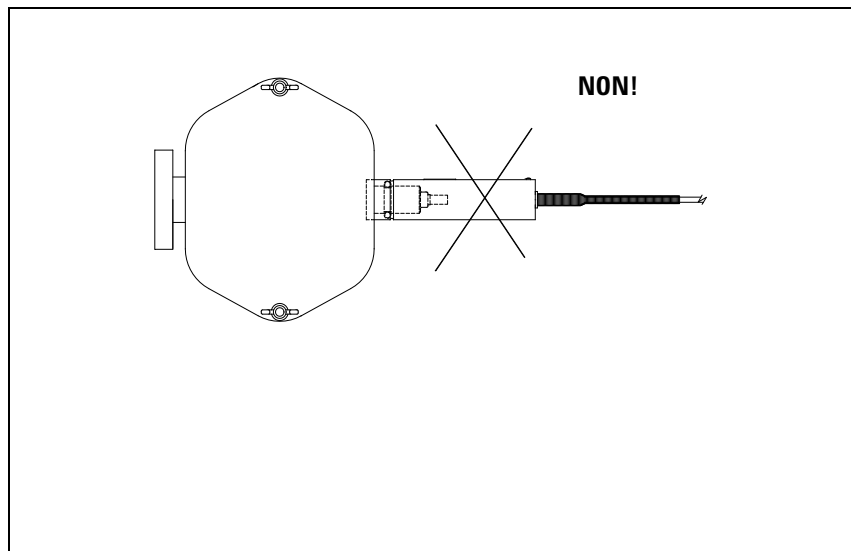

Figure 2

3 Procédure pour l'installation

Installation

AVERTISSEMENT!



Pour éviter toute lésion aux personnes, ne pas brancher la haute tension à la pompe avant que celle-ci soit installée dans le système et avant que toutes les brides d'entrées soient correctement assemblées ou fermées.

Le fonctionnement de la pompe n'est optimisé que si celle-ci est utilisée avec l'une des unités de contrôle Agilent spécifiques (4UHV ou MiniVac).

ATTENTION!

Lors de l'utilisation des pompes, le respect des normes de sécurité est impérativement subordonné à l'emploi des unités de contrôle Agilent.

La pompe Vaclon peut être installée dans toutes les positions. Par facilité elle est généralement montée en position verticale avec bride d'entrée en partie haute, ou en position horizontale.

Les pompes peuvent également être suspendues dans toutes les positions à l'aide de leur bride d'entrée.

Pour plus de détails sur l'installation de la pompe, consulter l'appendice "Technical Information".

Utilisation

Toutes les instructions pour le fonctionnement correct de la pompe Vaclon sont fournies dans la notice de l'unité de contrôle.

Il est conseillé de lire attentivement cette notice avant d'utiliser la pompe.

Des dépôts hygroscopiques et l'absorption d'hydrogène dans le composé de titane peuvent provoquer, par effet du vieillissement de la pompe, l'allongement du temps de démarrage. Pendant l'exposition à l'air, le dépôt du composé de titane absorbe de la vapeur d'eau et cette action a pour conséquence qu'au démarrage suivant le chauffage de la pompe entraînera la dispersion de la vapeur et d'une partie de l'hydrogène pompée précédemment ce qui aura pour effet d'allonger le temps de démarrage.

3 Procédure pour l'installation

Procédure d'utilisation

Procédure d'utilisation

Contrôler que la polarité de l'unité de contrôle soit correcte pour la pompe.

Se reporter au manuel correspondant et observer la procédure suivante pour l'utilisation de la pompe:

- 1 A l'aide d'une pompe de pré-vide, porter le système à une pression de 1×10^{-4} mbar, mieux 10^{-5} , ou inférieure.
- 2 Brancher l'unité de contrôle à une source d'alimentation appropriée et l'allumer.
- 3 Contrôler la tension, le courant et la pression. Une valeur de courant proche du courant de court-circuit de l'unité de contrôle révèle l'existence d'une fuite dans la pompe ou dans le système. Au cours de la phase de démarrage, un accroissement momentané de la pression de pré-vide est normal.
- 4 Laisser la soupape de pré-vide ouverte pendant le démarrage de la pompe ionique tant qu'une pression de démarrage appropriée n'a pas été atteinte. Si la tension de la pompe ionique descend après la fermeture de la soupape, la rouvrir pour un pré-pompage supplémentaire. Dès que la pression diminue, la tension remonte et la soupape de pré-vide doit être refermée.
- 5 Lorsque l'on porte la pompe à la pression atmosphérique, utiliser de l'azote sec de façon à éviter que les parois de la pompe n'absorbent de la vapeur aqueuse.

AVERTISSEMENT!

Lorsque la pompe est utilisée pour le pompage de gaz toxiques, inflammables ou radioactifs, suivre les procédures appropriées à chaque gaz. Ne pas utiliser la pompe en présence de gaz explosifs.

AVERTISSEMENT!



Eviter de toucher la pompe pendant les opérations de chauffage et de refroidissement. La température élevée peut provoquer des brûlures.

ATTENTION!

Ne pas approcher de dispositifs électroniques de la pompe. Le champ magnétique environnant cette dernière peut entraîner des dysfonctionnements de ces dispositifs.

Maintenance

Les pompes de la série Vaclon ne demandent aucun entretien. Toute intervention doit être exécutée par un personnel agréé.

AVERTISSEMENT!



Avant toute intervention sur la pompe, la débrancher de la haute tension.

En cas de mise au rebut d'une pompe, procéder à son élimination dans le respect des normes nationales en vigueur.

Mise au rebut

Signification du logo "WEEE" imprimé sur les étiquettes.

Le symbole ci-dessous est appliqué conformément à la directive CE nommée "WEEE".

Ce symbole (**uniquement valide pour les pays de la Communauté européenne**) indique que le produit sur lequel il est appliqué NE doit PAS être mis au rebut avec les ordures ménagères ou les déchets industriels ordinaires, mais passer par un système de collecte sélective.

Après avoir vérifié les termes et conditions du contrat de vente, l'utilisateur final est donc prié de contacter le fournisseur du dispositif, maison mère ou revendeur, pour mettre en œuvre le processus de collecte et mise au rebut.

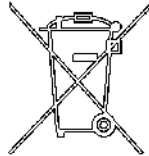

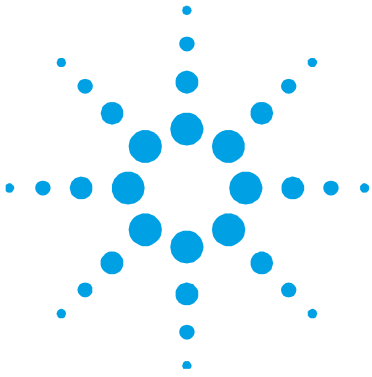

4 Installation procedure

General Information	40
Preparation for Installation	41
Installation	43
Use	45
Operating Procedure	46
Maintenance	47
Disposal	48

Original Instructions



General Information

This equipment is destined for use by professionals. The user should read this instruction manual and any other additional information supplied by Agilent before operating the equipment. Agilent will not be held responsible for any events occurring due to non-compliance, even partial, with these instructions, improper use by untrained persons, non-authorized interference with the equipment or any action contrary to that provided for by specific national standards.

The VacIon series pumps are ion pumps commonly used to create ultra-high vacuum, due to their cleanliness, ability to pump different gases, and maintenance- and vibration-free operation.

The following paragraphs contain all the information necessary to guarantee the safety of the operator when using the equipment. Detailed information is supplied in the appendix "Technical Information".

This manual uses the following standard protocol:

WARNING!



The warning messages are for attracting the attention of the operator to a particular procedure or practice which, if not followed correctly, could lead to serious injury.

CAUTION!

The caution messages are displayed before procedures which, if not followed, could cause damage to the equipment.

NOTE

The notes contain important information taken from the text.

Preparation for Installation

The pump is supplied in a special protective packing. If this shows signs of damage which may have occurred during transport, contact your local sales office.

When unpacking the pump, be sure not to drop it and avoid any kind of sudden impact or shock vibration to it.

Do not dispose of the packing materials in an unauthorized manner. The material is 100 % recyclable and complies with EEC Directive 85/399.

CAUTION!

In order to prevent outgassing problems, do not use bare hands to handle components which will be exposed to vacuum. Always use gloves or other appropriate protection.

NOTE

Normal exposure to the environment cannot damage the pump. Nevertheless, it is advisable to keep it closed until it is installed in the system, thus preventing any form of pollution by dust.

4 Installation procedure
Preparation for Installation

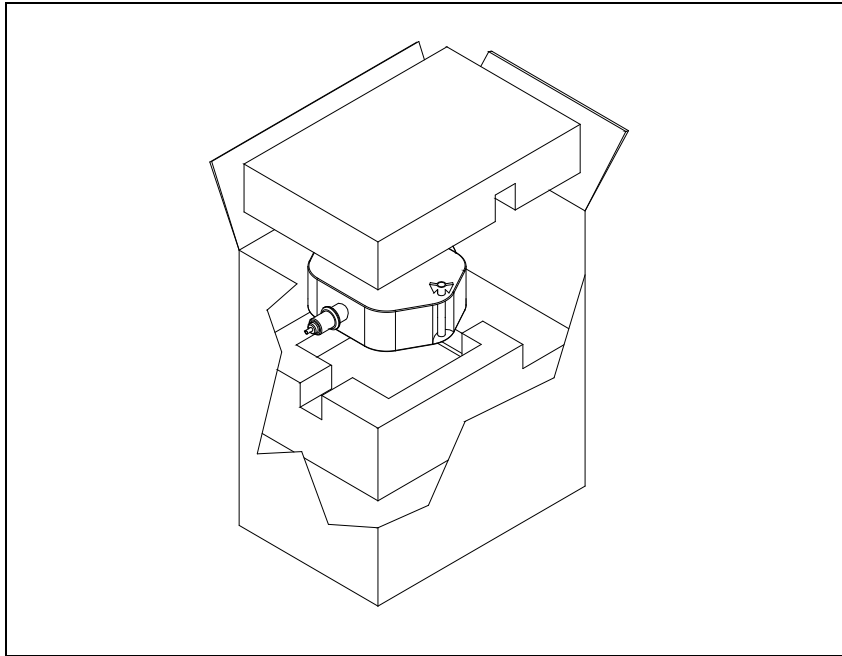

Figure 1

Installation

Do not install or use the pump in an environment exposed to atmospheric agents (rain, snow, ice), dust, aggressive gases, or in explosive environments or those with a high fire risk. During operation, to obtain the declared functioning specification, the ambient temperature must be between 0 °C and +85 °C.

CAUTION!

The pump should be kept sealed with its pinch-off tube until it is ready for attachment to the vacuum system.

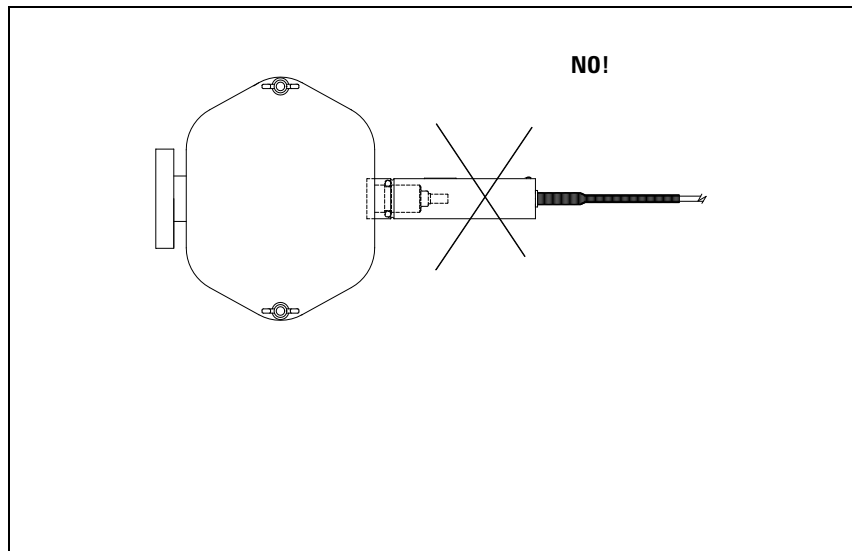

Figure 2

4 Installation procedure

Installation

WARNING!



To avoid injury, never connect the high voltage to the pump before it is installed into the system and all the inlet flanges are properly connected or blanked off.

The pump operation is optimized using one of the special Agilent controllers (4UHV or MiniVac) only.

CAUTION!

The safety specifications agreement using the pump is guaranteed using the Agilent controller only.

The VacIon pump can be installed in any position. For convenience, a pump is usually mounted vertically with the inlet up, or placed horizontally.

Pumps can be supported by the mounting flange in any position.

For detailed information about the pump installation, see the appendix “Technical Information”.

Use

All the instructions for the correct use of the VacIon pumps are contained in the control unit manual.

Read the manual carefully before using the pump.

Hygroscopic deposits and hydrogen absorption into titanium may cause starting times to increase with age. During exposure to air, the deposits of titanium compound absorb water vapor. In subsequent startups, pump heating causes release of the water vapor and some previously pumped hydrogen; thus, the starting time may be lengthened.

Operating Procedure

Check that the controller HV polarity is correct for the pump.

Refer to the relevant pump control unit instruction manual and follow the procedure below when operating the pump:

- 1 With a clean roughing pump, establish a roughing pressure of 1×10^{-4} , better 10^{-5} mbar or lower in the vacuum system.
- 2 Plug the control unit into a suitable power source and switch the power ON.
- 3 Observe the voltage, current, and roughing pressure. A current value near the short-circuit current of the control unit could indicate that an unconfined flow discharge exists in the pump or system. A temporary rise in roughing pressure will usually be noticed during any starting procedure.
- 4 Allow the roughing valve to remain open after turning on the ion pump until an adequate starting pressure is reached. If the ion pump voltage drops after closing the roughing valves, reopen the valve for additional rough pumping. As the pressure decreases, the voltage again will rise, and the roughing valve should be closed.
- 5 When venting the pump, use dry nitrogen. This will avoid water vapor absorption on the pump walls.

WARNING!



When employing the pump for pumping toxic, flammable, or radioactive gases, please follow the required procedures for each gas disposal. Do not use the pump in the presence of explosive gases.

WARNING!



Do not touch the pump during the heating and cooling phases. The high temperature may cause serious damage.

CAUTION!

Do not put any electronic device near the pump since the magnetic field may cause a device malfunction.

Maintenance

The Vaclon series pump does not require any maintenance. Any work performed on the pump must be carried out by authorized personnel.

WARNING!



Before carrying out any work on the pump, disconnect it from the High Voltage supply.

If a pump is to be scrapped, it must be disposed of in accordance with the specific national standards.

4 Installation procedure

Disposal

Disposal

Meaning of the "WEEE" logo found in labels.

The following symbol is applied in accordance with the EC WEEE (Waste Electrical and Electronic Equipment) Directive.

This symbol (**valid only in countries of the European Community**) indicates that the product it applies to must NOT be disposed of together with ordinary domestic or industrial waste but must be sent to a differentiated waste collection system.

The end user is therefore invited to contact the supplier of the device, whether the Parent Company or a retailer, to initiate the collection and disposal process after checking the contractual terms and conditions of sale.

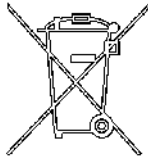

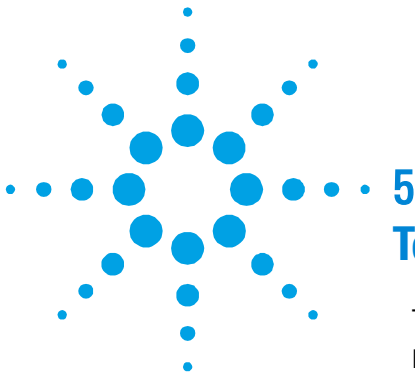

5 Technical Information

Technical Information	49
Description of the Vaclon Pump	50
Technical Specification	51
Outline Drawing	54
Stray Magnetic Field	55
Vaclon Pump Installation	58
Inspection Procedure	58
Visual Inspection	58
Vacuum Evaluation	59
Short Circuits	60
Typical Installation	61
Inlet Flange Connection	62
Control Unit Connection	63
Pump Connection	64
Bakeout Operation	64
Pump Speed & Noble Gases	66
Maintenance	67
Troubleshooting/Maintenance	68
10 l/s Vaclon Pump Replacement Parts and Accessories	70
10 l/s Vaclon Pump Controllers	71

Original Instructions



Description of the Vaclon Pump

The Agilent 10 l/s Vaclon pump is an ion pump and operates in the pressure range from 10^{-4} to below 10^{-11} mbar.

The 10 l/s Vaclon pump is housed in one compact package that virtually eliminates any stray magnetic field. The specifications make this pump ideal for general research, scanning electron microscopy, mass spectrometer pumping, and tube processing applications.

The standard 10 l/s Vaclon pump consists of:

- pump body with support brackets: model 919-5005
- magnet package: model 911-0030.

The following figure shows the 10 l/s Vaclon pump.

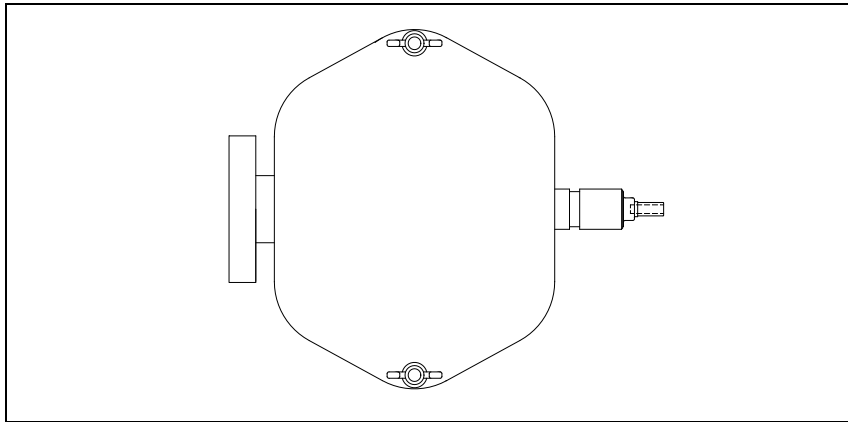

Figure 3 10 l/s Vaclon pump

Technical Specification

The following table details the main technical specifications of the 10 l/s VacIon pump.

Tab. 1

Specification	Value
Nominal pumping speed for Nitrogen (l/s)	10
Operating life at 1×10^{-6} mbar (hours)	40,000
Maximum operating voltage (Vdc)	+7000
Maximum starting pressure (mbar)	$\leq 1 \times 10^{-4}$
Ultimate pressure (mbar)	Below 10^{-11}
Inlet flange	Rotatable 2.75" (NW 35) OD ConFlat flange
Internal volume (litres)	0.4
Maximum baking temperature (°C)	350
Temperature limits (°C): Pump	400
Magnet	300
Material: Body	304 stainless steel
Magnet	Ferrite
Weight without magnet, lbs (kg)	9 (4)

5 Technical Information
Technical **Specification**

The following figure shows the typical pressure versus current diagram.

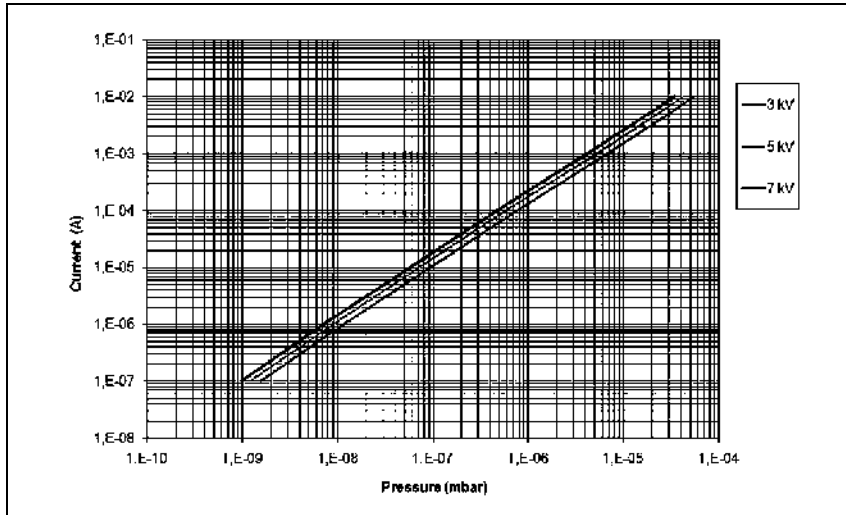

Figure 4 Typical pressure vs. current diagram

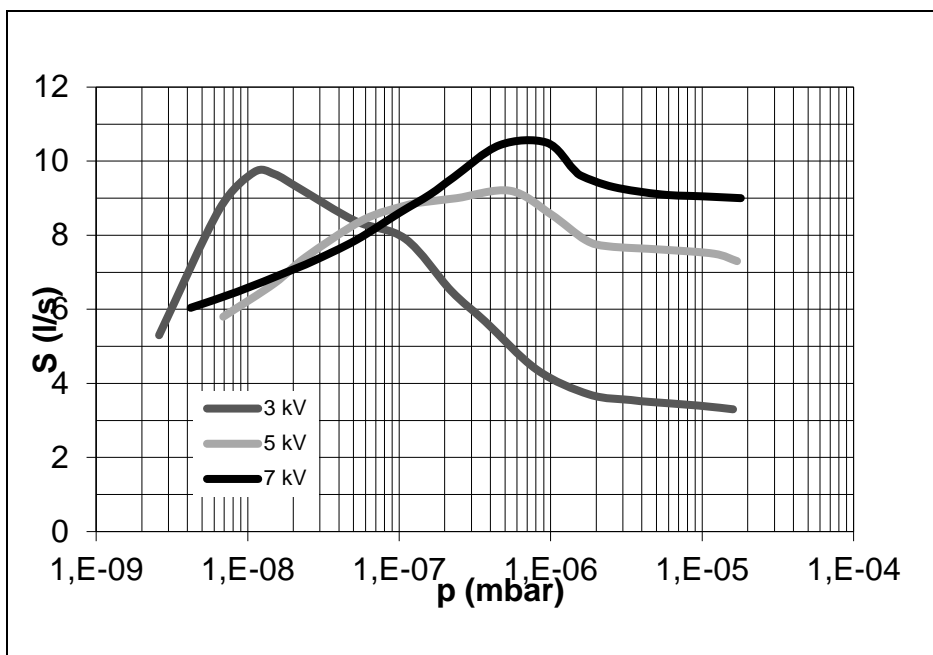

Figure 5 Typical pumping speed curve $S(p)$

Outline Drawing

The following figure shows the outline drawing for the 10 l/s Vaclon pump.

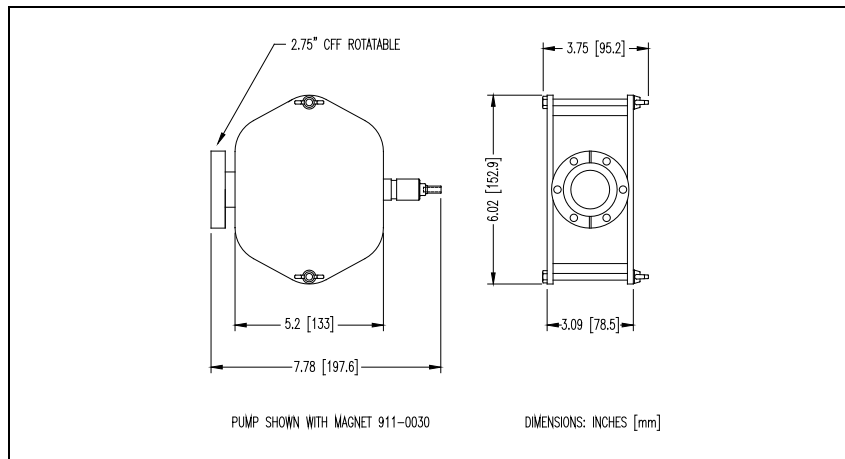

Figure 6 10 l/s Vaclon pump outline drawing

Stray Magnetic Field

Magnetic field data for the 10 l/s Vaclon pump and magnet package are provided in the plots below.

The following data are presented:

1. Magnetic field in gap of horseshoe and confined field magnets
2. 10 l/s pump magnet field free region
3. Magnetic field on pump flange axis
4. Magnetic field at flat of pump magnet package

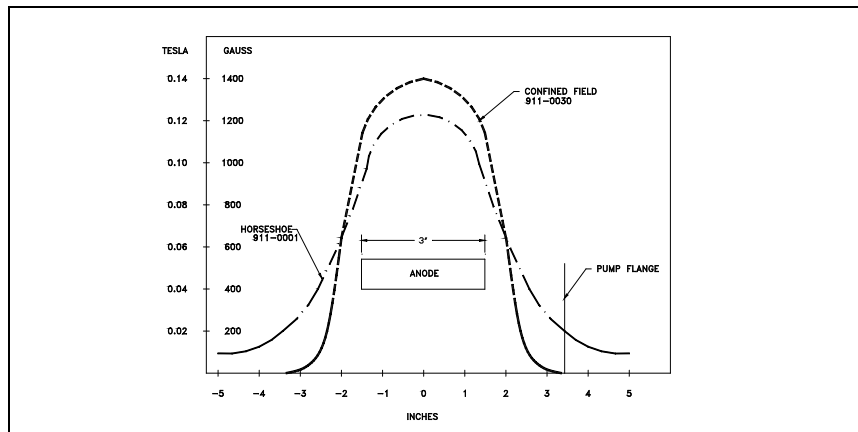

Figure 7 Magnetic field in gap of horseshoe and confined field magnets

5 Technical Information
Stray Magnetic Field

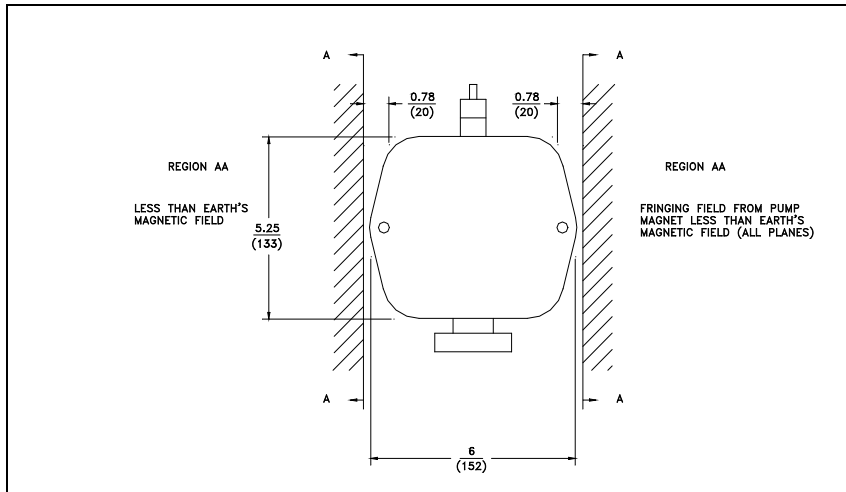

Figure 8 10 l/s pump magnet field free region

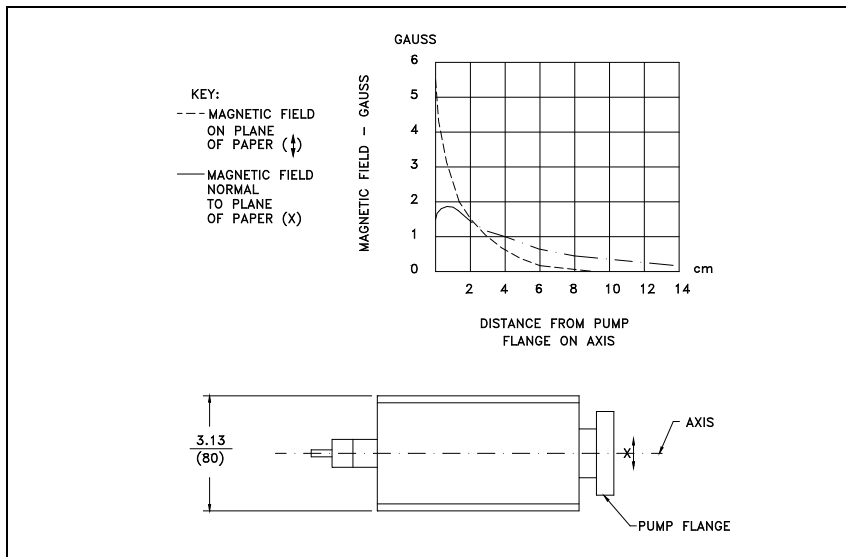

Figure 9 Magnetic field on pump flange axis

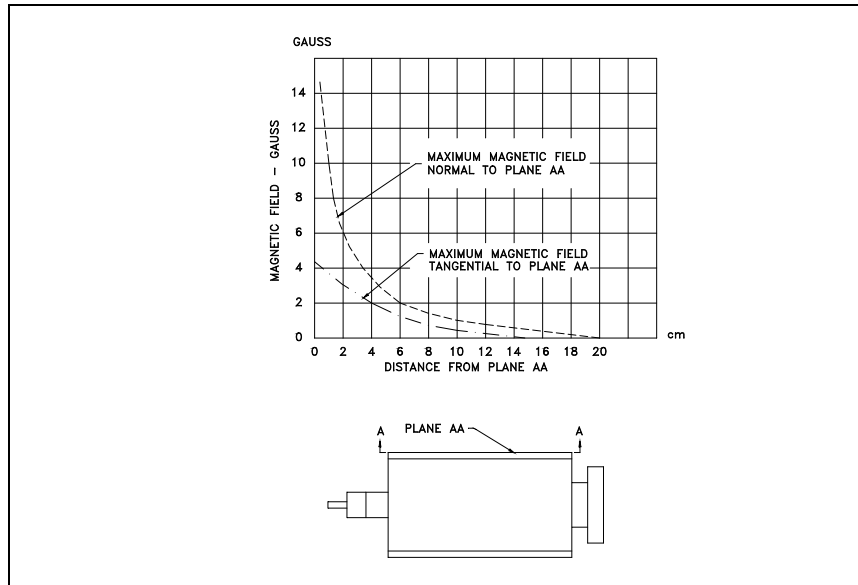

Figure 10 Magnetic field at flat of pump magnet package

Vaclon Pump Installation

Inspection Procedure

Vaclon pumps are evacuated, baked out, sealed and leak-checked at below 1×10^{-8} mbar prior shipping.

The following information and procedures can be used to establish the vacuum integrity of a Vaclon pump before installation.

Visual Inspection

Inspect the pump and magnet for physical damage which may have occurred during shipment. Examine, in particular, the brazed joints on the high voltage feedthrough.

Inspect the pinch-off seal. If it is open, the pump is at atmospheric pressure.

WARNING!

The pinch-off seal is extremely sharp. Be careful.



A Vaclon pump that has been exposed to atmosphere during shipment, or while in storage, will operate properly if it has otherwise not been damaged.

The pump is not harmed by such exposure, although it is good practice to keep it under vacuum when not in use to exclude dust and the accumulation of water vapor from the environment.

Vacuum Evaluation

To determine the vacuum level of the new pump before air releasing it:

- 1 Connect the pump to the control unit as directed in the instruction manual of the control unit.
-

WARNING!



The high voltage which is present in the ion pump when it is powered from the power unit can cause severe injury or death. Be sure the garter spring is mounted on the high voltage feed through because the ground connection is brought from the control unit to the pump body through the garter spring. An additional safety ground connection for the pump body is made through the fixing screws of the H.V. cable connector.

- 2 With the main power switch in the OFF position, plug the control unit into a suitable power source.
- 3 Turn the power to ON.
- 4 Observe the reading for an indication of one of the following conditions:
 - a If the pump is free of leaks and is at a low pressure, the pressure indication shall quickly fall to or below the 10^{-8} mbar range as the volume of gas is pumped.
 - b If the pressure inside the pump is at or near atmospheric level, an arc may strike inside the high voltage feedthrough giving a popping sound and the pump current will fluctuate. If this occurs, turn the power OFF immediately.
- 5 If the vacuum integrity has been lost, the pump should be leak-checked with a mass spectrometer leak detector before installation on the system.
- 6 With the control unit disconnected, break the pinch-off seal on the copper tubulation with pliers, diagonal cutters or a prick punch. The sound of inrushing air indicates a well-sealed pump.

5 Technical Information

Vaclon Pump Installation

CAUTION!

Do not open the pinch off-seal with a saw or grinder. These methods will cause metal particles to be drawn into the pump by the inrushing air as the pump is opened.

NOTE

To prevent water vapour or dust particles from entering the pump, leave the pinch-off tubulation (tube flange assembly) sealed until ready to attach the pump to the vacuum system.

Short Circuits

If there is a short circuit between the anode and cathodes in the pump, the short-circuit current of the control unit will be drawn and zero voltage will be indicated. If a short circuit exists in the control unit or high voltage cable and connector, zero voltage will also be observed when the high voltage connector is disconnected from the pump (refer to the control unit manuals).

Typical Installation

A typical installation is shown in the following figure and consists of:

1. VacIon pump.
2. A valve to seal off the pump from the rest of the system (if required).
3. The control unit.
4. A clean roughing pump (i.e. turbo or sorption).
5. A thermocouple gauge capable of indicating pressure from atmosphere to 10^{-3} mbar range.
6. A valve to seal off the roughing pump from the vacuum chamber.
7. High voltage cable.
8. Backing pump.

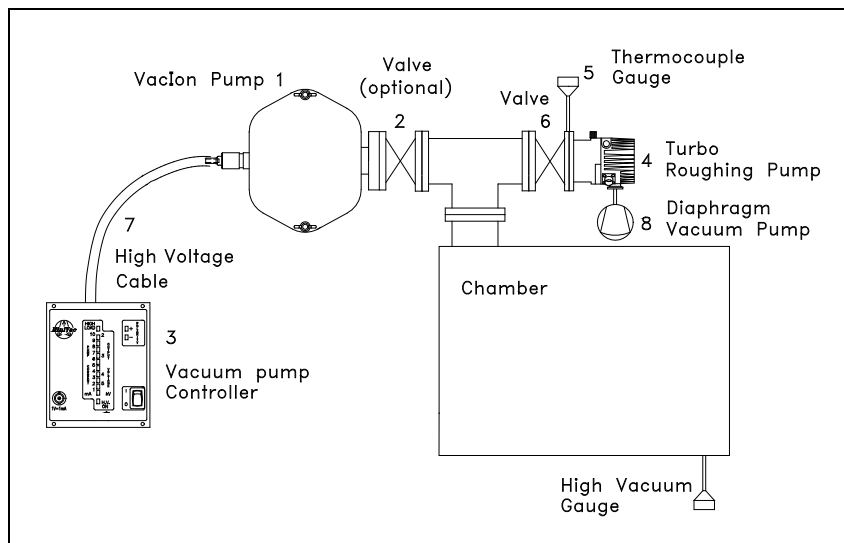

Figure 11 Typical installation

Inlet Flange Connection

The VacIon pump can be installed with any orientation.

For convenience, a pump is usually mounted vertically with the inlet up, or placed horizontally.

Pumps can be supported by the mounting flange in the vertical position.

When mounted horizontally, or when transported, all pumps should be supported.

The pump should be mounted to fulfill two space requirements.

First, a minimum of clearance is necessary for the removal of the high voltage connector.

Second, the effect of the pump fringing magnetic field should be considered.

The stray field is lowest along a line passing through the magnet assembly in the long direction. If magnetic shielding is necessary, place the shield around the experiment itself. Refer to specifications for stray magnetic field data.

To avoid accumulation of dust and other particles or foreign material, the pump should be kept sealed with its pinch-off tubulation until it is ready for attachment to the vacuum system.

When ready to install the pump, unscrew the main flange bolts and lift the blank flange with the help of a bolt screwed into the available threaded hole. If the pump is equipped with a rotatable flange, support the lower part of the flange with a piece of wood placed between flange and pump body.

NOTE

Some particles of copper oxide may adhere to the outer edge of the flange gasket. Be careful not to allow them or any other foreign materials to fall into the pump.

Connect the pump to the system with tubing of the largest practical diameter. This tubing should be as short as possible to avoid a large pressure differential between the VacIon pump and the system.

Then proceed as follows:

- 1 Inspect the mating flanges for cleanliness and large scratches or nicks.
- 2 Use a new gasket each time the flanges are reassembled.
- 3 Use washers with all flanges except 2.75" o.d. flanges. Use type 300-series stainless steel screws, nuts, and washers for the required strength and thermal expansion.
- 4 Use silver-plated screws or apply high-temperature lubricant to the screw threads that extend through the flange and between the nuts and flange. Proper lubrication facilitates tightening and disassembly. A recommended lubricant for use on the outside of pumps is Fel-Pro C-100.

NOTE

Lubrication is essential to prevent galling of the nut and screw after bakeout.

- 5 Attach the nuts and tighten each one to 6 – 11 Nm (4.5 - 8 ft.-lbs) of torque. This will partially close the gap between the flange faces.
- 6 Repeat the sequential tightening for two more cycles.
- 7 Continue tightening the bolts until the flange faces meet and a pronounced increase in torque is felt.

Control Unit Connection

An Agilent VacIon pump control unit is recommended for use with all pump sizes.

WARNING!



Before connecting the equipment to the power source, an earth ground should be connected to the control unit's ground bar, and a connection with the VacIon pump must be established.

Pump Connection

WARNING!



Never apply power until you have checked and verified that proper grounding has been achieved (refer to the relevant ion pump control unit instruction manual).

The pump is connected to the control unit by a co-axial high voltage cable assembly as follows:

- 1 Check that the unit's main power switch is OFF.
 - 2 Where applicable, ground the pump body to the control unit by fastening the braided ground lead from the control unit to the pump body.
 - 3 Position the "grounding spring" on the pump voltage feedthrough in the recess between the ceramic and the weld sleeve.
 - 4 Push the cable connector over the high voltage feedthrough.
 - 5 Always twist the connector until the cable connector slides over the grounding spring and goes no further.
 - 6 Where a connector bracket is installed, tighten the screw.
-

WARNING!



Before disconnecting the high voltage connector from the pump, wait at least 30 seconds after turning off the high voltage to allow the capacitors to discharge completely.

Bakeout Operation

When a VacIon pump does not reach the desired ultimate pressure, and there are no leaks, it is necessary to bake the system to remove water vapour. This is done by heating the pump and all the components in the system.

- 1** Heat the pump body and the system with a bakeout oven unit or heating strips to temperatures between 150 °C and 220 °C (220 °C is the maximum allowable for most bakeable high voltage cables). This temperature is high enough to degas the pump surfaces of water vapour without damaging the magnet and high voltage connector. Note that the system components must be compatible with the bakeout temperature. The heating must be approximately even on all vacuum surfaces or water vapour can re-condense on the cooler surfaces preventing of UHV vacuum pressures.
- 2** Leave the pump control unit on and monitor the pressure. It must never increase above 5×10^{-5} mbar; if this value is exceeded, turn the bakeout off and then on again when low pressure is restored. To control the heaters and to monitor to high pressure limit during bakeout in automatic mode, a pressure-sensitive relay may be used.
- 3** Bake the VacIon pump for at least eight hours. Longer bakeout periods are recommended when the pump has been used with heavy gas load or when UHV pressure, 10^{-9} mbar or less is desired.
- 4** As the pump and system cool down to room temperature, a drop in pressure should be observed.

Pump Speed & Noble Gases

Pumping speed varies with pressure and with different gases.

Virtually all gases and vapours can be pumped without stopping the pumping action in VacIon pumps. The sputtering action of the pump removes contaminants and continues to provide fresh titanium for pumping. An inert gas load in a vacuum system is typically only "volume gas" - inert gas absorption to surfaces of the system is negligible. Thus, the need for long-term inert gas pumping only occurs when argon or air is introduced continuously into the system or if a large leak exists (argon is 1 % of atmospheric air). Diode pumps have normally a low pumping speed for inert gases typically 2 – 3% of their nominal pumping speed. Instability, cyclical pressure increases, typically occur after pumping inert gas amount equal to pure inert gas for 20 h at 10^{-6} mbar.

NOTE

This pump is designed to have a higher pumping speed (~ 20%) for inert gases, but it is still a diode design. Therefore instability occurs after shorter time as the critical amount of gas is pumped away faster.

Maintenance

WARNING!



The high voltage present in the high voltage cable which connects the control unit to the ion pump can cause severe injury or death. Before mounting the high voltage connector of the cable on the pump high voltage feedthrough, or before removing it, be sure the main power is removed from the control unit. Before removing the high voltage connector of the cable from the control unit, be sure the main power is removed from the control unit. Wait at least 10 seconds after removing the main power from the control unit, to allow capacitors to discharge completely.

VacIon pumps are maintenance free. In case of life time expiry or accidental premature failure of the pump, please contact your nearest Agilent sales/service office for repair.

Troubleshooting/Maintenance

The need for appropriate maintenance is indicated by one or more of the following conditions:

- 1 Pump current fluctuation, internal electrical shorts, or pressure bursts.**
These are usually caused by titanium compounds flaking from surfaces as the pump accumulates operating time.
- 2 Slow starting.**
The pump may require more time to start after exposure to air compared to starting times experienced when the pump was new, even though a good roughing system with high pumping speed for water vapour is used. Assuming that the vacuum system has not been contaminated, this condition is usually caused by water vapour absorbed on the surface area inside the pump. An increase of surface area is caused by titanium compound deposits, which are hygroscopic. Care should be taken to thoroughly remove cleaning solvents from the high voltage feedthrough well and other areas that could trap the solvents.
- 3 Slow pump-down.**
This condition can be caused by foreign material in the system or pump. An example is molecular sieve material from a trap or a sorption pump drawn into the vacuum system by accidental opening of the roughing valve at high pressure. This will cause molecular sieve particles to be deposited throughout the pump and vacuum system. Slow pump-down caused by a leak can be quickly recognized because the pressure will reach and maintain a constant level. Most outgassing phenomena decrease with pumping time, although sometimes slowly.
- 4 Hydrogen saturation of sputter-cathode grids.**
Pumping hydrogen at a true pressure of 1×10^{-5} mbar for about 1500 hours will saturate the sputter-cathode grids. The time for saturation decreases rapidly at true pressures above 1×10^{-5} mbar. (It is important to note that the pressure indicated by the pump current or shown on an ionization gauge calibrated for nitrogen must be multiplied by 2.2 to obtain the true pressure of hydrogen.)
In the event of hydrogen saturation of the cathode grids, replace the pump element. It is possible to achieve some regeneration by baking for at least 24 hours.

5 Cathode erosion.

The cathode adjacent to each anode cell may become extremely eroded after the pump element has been used for a long time. Replace the sputter cathodes of a triode pump when one or more titanium vanes are nearly eroded through at the centres of the anode cells.

6 Short circuit across insulators.

Short circuits may result from flakes or foreign materials. Continuous arcs can melt sputter shields and coat the ceramic insulators. Inspect insulator surfaces and sputter shields. Remove foreign materials as necessary. On pumps that do not have removable elements, tap the pump firmly to dislodge flakes that may be causing the short circuit.

7 Field emission current.

A background (leakage) pump current is often caused by field emission which reduces the accuracy of using the pump current as a pressure indicator.

Check the Vaclon leakage currents as follows:

- a) Turn off the pump control unit.
- b) Remove the pump magnet(s).
- c) Connect and turn on the pump control unit and wait for current stabilization. Meter must indicate less than 1 mA. Make sure that the control unit and high voltage cable leakage current is negligible.

If leakage currents come from the pump, perform the "hi-potting" by applying 10 to 12 kV (ac) at a current of 30 to 50 milliamperes for less than 1 minute. This power will burn off all sharp edges which are sources of the leakage currents.

WARNING!



Voltages developed in the high-potter power supply are potentially lethal. Use caution during operation and ensure correct grounding connection.

-
- e) Check the pump leakage currents and install the magnet.

10 l/s Vaclon Pump Replacement Parts and Accessories

Tab. 2

	Part number
10 l/s Vaclon pump, processed, w/ 2-3/4" flange	919-5005
Magnet assembly for 10 l/s Vaclon pump	911-030
Cables	
HV Bakeable cable, 13' (4 m), straight, FISCHER-HV	929-0712
10' (3 m) cable with right angle connector, KING-HV	924-0741

For a complete overview of Agilent's extensive vacuum product line, please refer to the Agilent Vacuum Catalogue.

10 l/s Vaclon Pump Controllers

Tab. 3

Controller model		Part number
MiniVac	120 Vac, KING-HV	929-0190
	220 Vac, KING-HV	929-0291
	24 Vdc, KING-HV	929-0197
MiniVac	120 Vac, FISCHER-HV	929-0191
	220 Vac, FISCHER-HV	929-0290
	24 Vdc, FISCHER-HV	929-0196
4UHV	1 x 120W positive	929-9101
	1 x 200W positive	929-9011
	2 x 80 W positive	929-9201
	4 x 80 W positive	929-9401
19" rack adapter for MiniVac		969-9191
19" rack adapter for 4UHV		929-0064

Please refer to the Agilent Vacuum Catalogue to choose the correct controller.



Agilent Technologies

Vacuum Products Division

Dear Customer,

Thank you for purchasing an Agilent vacuum product. At Agilent Vacuum Products Division we make every effort to ensure that you will be satisfied with the product and/or service you have purchased.

As part of our Continuous Improvement effort, we ask that you report to us any problem you may have had with the purchase or operation of our products. On the back side you find a Corrective Action request form that you may fill out in the first part and return to us.

This form is intended to supplement normal lines of communications and to resolve problems that existing systems are not addressing in an adequate or timely manner.

Upon receipt of your Corrective Action Request we will determine the Root Cause of the problem and take the necessary actions to eliminate it. You will be contacted by one of our employees who will review the problem with you and update you, with the second part of the same form, on our actions.

Your business is very important to us. Please, take the time and let us know how we can improve.

Sincerely,

Giampaolo LEVI

***Vice President and General Manager
Agilent Vacuum Products Division***

CUSTOMER REQUEST FOR CORRECTIVE / PREVENTIVE / IMPROVEMENT ACTION

TO: AGILENT VACUUM PRODUCTS DIVISION TORINO – QUALITY ASSURANCE

FAX N°: XXXX-011-9979350

ADDRESS: AGILENT TECHNOLOGIES ITALIA S.p.A. – Vacuum Products Division –

Via F.lli Varian, 54 – 10040 Leinì (TO) – Italy

E-MAIL: vpd-qualityassurance_pdl-ext@agilent.com

NAME _____	COMPANY _____	FUNCTION _____
ADDRESS: _____		
TEL. N° : _____ FAX N° : _____		
E-MAIL: _____		
PROBLEM / SUGGESTION : _____ _____ _____ _____		
REFERENCE INFORMATION (model n°, serial n°, ordering information, time to failure after installation, etc.): _____ _____ _____		
		DATE _____
CORRECTIVE ACTION PLAN / ACTUATION (by AGILENT VPD) _____ _____ _____ _____ _____		LOG N° _____

XXX = Code for dialing Italy from your country (es. 01139 from USA; 00139 from Japan, etc.)



**Vacuum Products Division
Instructions for returning products**

Dear Customer:

Please follow these instructions whenever one of our products needs to be returned.

- 1) Complete the attached Request for Return form and send it to Agilent Technologies (see below), taking particular care to identify all products that have pumped or been exposed to any toxic or hazardous materials.
- 2) After evaluating the information, Agilent Technologies will provide you with a Return Authorization (RA) number via email or fax, as requested.
Note: Depending on the type of return, a Purchase Order may be required at the time the Request for Return is submitted. We will quote any necessary services (evaluation, repair, special cleaning, eg).
- 3) **Important steps for the shipment of returning product:**
 - Remove all accessories from the core product (e.g. inlet screens, vent valves).
 - Prior to shipment, drain any oils or other liquids, purge or flush all gasses, and wipe off any excess residue.
 - If ordering an Advance Exchange product, please use the packaging from the Advance Exchange to return the defective product.
 - Seal the product in a plastic bag, and package product carefully to avoid damage in transit. You are responsible for loss or damage in transit.
 - Agilent Technologies is not responsible for returning customer provided packaging or containers.
 - **Clearly label package with RA number.** Using the shipping label provided will ensure the proper address and RA number are on the package. Packages shipped to Agilent without a RA clearly written on the outside cannot be accepted and will be returned.
- 4) Return only products for which the RA was issued.
- 5) **Product being returned under a RA must be received within 15 business days.**
- 6) **Ship to the location specified on the printable label, which will be sent, along with the RA number, as soon as we have received all of the required information.** Customer is responsible for freight charges on returning product.
- 7) Return shipments must comply with all applicable **Shipping Regulations** (IATA, DOT, etc.) and carrier requirements.

RETURN THE COMPLETED REQUEST FOR RETURN FORM TO YOUR NEAREST LOCATION:

EUROPE:	NORTH AMERICA:	PACIFIC RIM:
Fax: 00 39 011 9979 330 Fax Free: 00 800 345 345 00 Toll Free: 00 800 234 234 00 vpt-customer@agilent.com	Fax: 1 781 860 9252 Toll Free: 800 882 7426, Option 3 vpl-ra@agilent.com	please visit our website for individual office information http://www.agilent.com



Vacuum Products Division
Request for Return Form
(Health and Safety Certification)

Please read important policy information on Page 3 that applies to all returns.

1) CUSTOMER INFORMATION

Form with fields: Company Name, Contact Name, Tel, Email, Fax, Customer Ship To, Customer Bill To, VAT reg. Number, USA/Canada only, Taxable, Non-taxable

2) PRODUCT IDENTIFICATION

Table with 4 columns: Product Description, Agilent P/N, Agilent S/N, Original Purchasing Reference

3) TYPE OF RETURN (Choose one from each row and supply Purchase Order if requesting a billable service)

- 3A. [] Non-Billable [] Billable -> New PO # (hard copy must be submitted with this form):
3B. [] Exchange [] Repair [] Upgrade [] Consignment/Demo [] Calibration [] Evaluation [] Return for Credit

4) HEALTH and SAFETY CERTIFICATION

AGILENT TECHNOLOGIES CANNOT ACCEPT ANY PRODUCTS CONTAMINATED WITH BIOLOGICAL OR EXPLOSIVE HAZARDS, RADIOACTIVE MATERIAL, OR MERCURY AT ITS FACILITY. Call Agilent Technologies to discuss alternatives if this requirement presents a problem. The equipment listed above (check one): [] HAS NOT pumped or been exposed to any toxic or hazardous materials. OR [] HAS pumped or been exposed to the following toxic or hazardous materials. If this box is checked, the following information must also be filled out. Check boxes for all materials to which product(s) pumped or was exposed: [] Toxic [] Corrosive [] Reactive [] Flammable [] Explosive [] Biological [] Radioactive List all toxic/hazardous materials. Include product name, chemical name, and chemical symbol or formula: NOTE: If a product is received at Agilent which is contaminated with a toxic or hazardous material that was not disclosed, the customer will be held responsible for all costs incurred to ensure the safe handling of the product, and is liable for any harm or injury to Agilent employees as well as to any third party occurring as a result of exposure to toxic or hazardous materials present in the product. Print Name: Authorized Signature: Date:

5) FAILURE INFORMATION:

Failure Mode (REQUIRED FIELD. See next page for suggestions of failure terms): Detailed Description of Malfunction: (Please provide the error message) Application (system and model):

I understand and agree to the terms of Section 6, Page 3/3. Print Name: Authorized Signature: Date: